

## LEARNING FROM HALE

*An Educational Augmented Reality for an Indigenous Hawaiian Architecture*

RICHARD ROBINSON<sup>1</sup> and HYOUNG-JUNE PARK<sup>2</sup>

<sup>1,2</sup>*School of Architecture, University of Hawaii at Manoa*

<sup>1</sup> *rrrobins@hawaii.edu* <sup>2</sup> *hjpark@hawaii.edu*

**Abstract.** An educational Augmented Reality (AR) application with Head Mount Display (HMD) is developed for the revitalization of the Hales. The proposed application allows a user to have a dynamic learning experience of the Hale by 1) full immersion into an extended reality, 2) enabling the hands-on construction & assembly process with real-time feedback, and 3) visualizing context-specific information and concepts. Through this intact experience, tacit knowledge embedded in the Hawaiian Hale design is delivered. In this paper, the implementation of the proposed application is explained, and the usage of the application is also demonstrated.

**Keywords.** Augmented Reality; Tacit Knowledge; Cultural Heritage; Hale; SDG 4.

### 1. Introduction

Hale, a traditional Hawaiian house, has diminished in and lost its ground from the landscape in Hawaii. The revitalization of traditional hale is an opportunity for community gathering, and the restored structure itself has become a place for teaching (Abemathy et al, 1978; Bryan, 1950). Tacit knowledge embedded in Hale design serves to revive and restore the traditional building practices and instil pride that comes from living traditional Hawaiian values (Edwards 2019; Apple, 1971; Buck, 1957). However, such tacit knowledge has been an elusive subject due to its difficulty to be articulated, recorded, and communicated (Dampney et al, 2002). Furthermore, the oral tradition for transferring the tacit knowledge in Hawaii makes more difficult to convert it to explicit knowledge (Nonaka and Takeuchi, 1995) for the future generation of Hawaii.

Augmented Reality (AR) serves to create a reality that is supplemental to the physical environment (Caudell and Mizell, 1992). AR provides new possibilities for innovative education, and they have been increasingly recognized by educational researchers (Hashimoto and Park, 2020). By adding an enhanced layer of computer-generated information to the real-world environment, AR allows a user to 1) interact with two- and three-dimensional synthetic objects in real-time, 2) visualize context-specific complex spatial relationships and abstract concepts, and 3) experience phenomena with a full-scale immersion (Hashimoto and Park, 2020; Arvanitis et al.,

2007). In the area of Cultural Heritage (CH) education, the implementation of AR is already acknowledged to improve a student's learning experience and motivation (Gonzales Vargas et al., 2020). AR allows users to experience how people used to live within Cultural Heritage (CH) rather than structures or objects of the past (Voinea et al., 2018). With the help of AR, many breakthroughs of preservation, documentation, and exploration of CH have been made by different professions such as archaeologists, researchers, or museum curators (Bekele et al, 2018; Cozzani et al, 2019).

In this paper, an educational Augmented Reality (AR) application with Head Mount Display (HMD) for learning Hale, an indigenous Hawaiian architecture, is proposed for reviving Hale as a place for community gathering and teaching. Including Hale Wa'a, four different types based upon the specific function and purpose for its residents have been studied for the development of the application. Rhinoceros 3D and its visual programming language Grasshopper 3D are employed with Fologram plugin for AR environment. This proposed application consists of 1) initiation of AR + assembly procedures, and 2) Hale in AR: geometric model, text tag, and diagrams. The assembly process of Hale Wa'a is demonstrated within the proposed application.

## 2. Hale

Between 124 and 1120 AD, the Hawaiian Islands were first settled by Polynesians, and the Hawaiian civilization was born (Buck, 1957). For the next 500 years, this civilization was isolated from outside contact, and from this isolation, Hawaiian culture was created. Due to the warm climate of the Hawaiian Islands, the shelters created by the Hawaiian people were well adapted to the tropics and provided storage and/or protection against rough weather. Hawaiian Hales are either single houses or complex houses for chiefs and nobles of the island. The Hale is made from grass and is a wooden framework consisting of a ridgepole, rafters, and purlins. Hawaiian Hales typically had a small door and no windows. The building practices of Hawaiian Hale's also incorporate tacit knowledge such as building materials, techniques, and environmental design (Edwards 2019).

The Hawaiian Hale adapted to change after the islands made first contact with missionaries, by rearranging and adopting a new belief system that affected how the hale was built and used. The changes introduced concepts of domestic privacy in contrast with Hawaiian household ideas of "freedom of access" (Aikau and Gonzales, 2019). Similarly, when the Hawaiian language was banned in the late 1800s the culture behind the language was almost lost due to the influence of colonization (Nakata, 2017). The language was revitalized over a hundred years later in the late 1900s and preserved by the native people so it can be passed down and taught to the next generations (Warschauer and Kuamo'yo, 1997). Augmented Reality is a tool that can be used as a means to preserve the culture behind Hales so the information can be passed on to later generations, similar to the Hawaiian language. By preserving tacit knowledge of Hale through AR, institutions like schools and cultural museums can teach the cultural significance behind the Hale of the Hawaiian settlers.

Traditional Hawaiian Hale can be categorized by the ROH (the Revision Ordinance of Honolulu) into four different types of classic Hale styles. These unique styles include A-Frame (Hale Wa'a), open wall (Halawai), lean-to (Ku'ai), or fully enclosed (Noa). In addition, each variety of Hale are used for specific functions including eating,

sleeping, assembling, retailing, and storage (Kilolani and Middlesworth, 1992). The following Hale Wa'a was used for eating, storage, retailing and assembly.

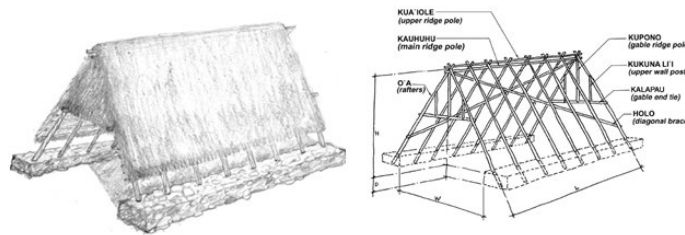

Figure 1. Diagram of Hale Wa'a and Framework (City and County of Honolulu, 2021)

All the four different types of the Hale have been studied for 1) creating the historical and cultural contents, 2) developing geometric models, and 3) translating the assembly process of the Hale into a sequence of design actions with the models as shown in Figure 6.

### 3. Augmented Reality (AR) with Head Mount Display (HMD)

An extended reality (Kaplan et al, 2020) for learning the Hale through its assembly process is implemented with 1) Rhinoceros3D, 2) Grasshopper3D, and 3) Fologram.

#### 3.1. INITIATION OF AR + ASSMBLY PROCEDURES

Rhinoceros3D is used for the geometric modelling of the Hale. Its geometric data are translated into Grasshopper3D for the synchronization of the geometric model to the layer of augmented reality through Fologram.

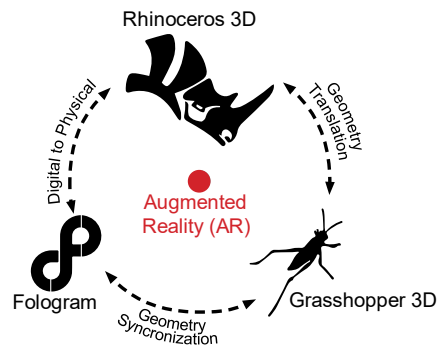

Figure 2. AR framework with Rhinoceros 3D, Grasshopper 3D, and Fologram

In setting up the application, the geometric models of Hale necessary for its construction are developed in Rhinoceros 3d. The geometric models reflect what the physical structure should closely resemble in AR. The first part of the script is used to display the wireframe component of the digital model. Used in unison with Fologram, the wireframe of the model is displayed to the user first indicating the size and scale of the model prior to assembly.

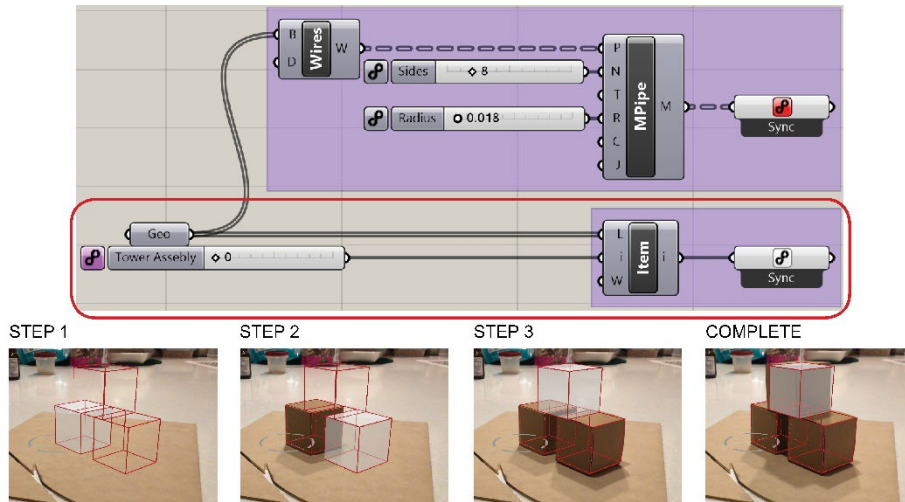

Figure 3. Wireframes of geometric models and Assembly Steps in AR

The second part of the script involves a “parameter” script that controls the assembly steps as shown in figure 5. The script of the digital model in wireframe and its parameter controller are connected to a “list index” script. The “parameter” script then allows the user to cycle through all the connected geometries in the “list index”. By utilizing the “parameter” script, the portion of the model will be highlighted for notifying the targeted object and its placement before moving to the next step in the assembly procedures as shown in Figure 3. The two-way arrow between Fologram and Grasshopper 3D specifically affects the instructional parameters that get ported from grasshopper to the Fologram app, so if the user goes from step 1 to step 2 in Fologram, Grasshopper updates the digital model in Rhinoceros to reflect the assembly step that the user is working on. The user would use AR as a guiding system for the construction of a Hale. Also, the proposed AR allow the user to deviate from the instructions for further exploration.

### 3.2. HALE IN AR: GEOMETRIC MODEL, TEXT TAG, AND DIAGRAM

To create the assembly process in AR, a digital collection of all the different Hale styles and variations needs to be established. By having each model, the assembly can be broken down into pieces and the Grasshopper3D script can be utilized to create the assembly steps. The collection allows a user to cycle through each holographic model prior to engage in its assembly process. The construction of Hale Wa'a is demonstrated with AR in this paper. The Fologram add-on “text tag” becomes movable texts including historic and cultural contents of the Hale. The text tag follows the user’s visual focus through the assembly build as its guidance as shown in Figure 4. In addition to the geometric modelling of the Hale and the text tag, various skill sets embedded in Hale design including lashing, thatching, stacking, and securing are illustrated with any diagrams and images through the panels in AR environment. The diagrams and images had to be saved as images files such as JPEG and added to the

Grasshopper script as textures. The diagram of tie lashings to the Hale is shown in Figure 5.

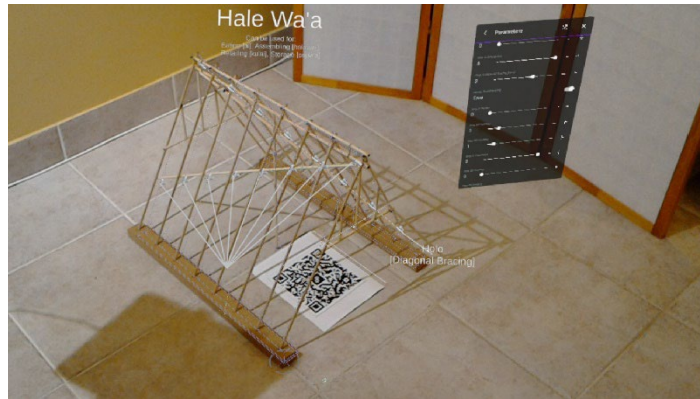

Figure 4. Text tag within AR

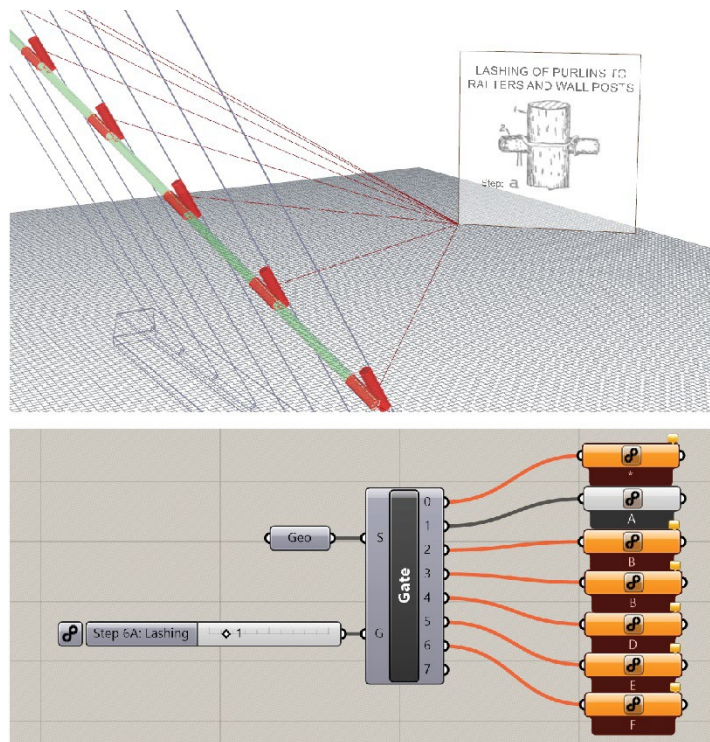

Figure 5. Overlaid Diagrams for Assembly Instructions

After implementing the visualization of the text and diagrams within the AR environment, toggle options are developed for hiding and showing the layers of four different information: master text, titles, parts, and diagrams. This layering system with the toggle options controls the four types of the visualized information according to a user's need.

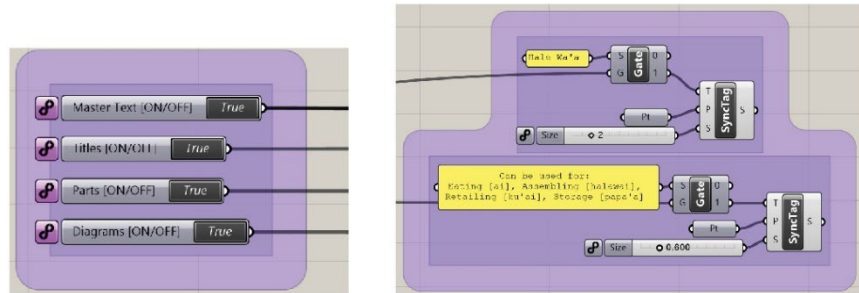

Figure 6. Controlling the information layers with toggle options

From compiling each part of the digital model in Rhinoceros3D and finalizing the Grasshopper3D script with the Fologram tags and diagrams, the AR-based Hale assembly is ready for proceeding with Microsoft HoloLens, a head mount display.

#### 4. Assembly of Hale Wa'a

The Hale Wa'a, shown in figure 1, involved seven steps to the assembly from start to finish. As additional steps to the assembly, sub-steps were added to include visual instructions of the lashing diagrams. the seven steps are 1) Pa Pohaku (Foundation Walls), 2) O'a (Rafters), 3) Pou Hana (Ridge Post) & Kauhuhu (Ridge Pole), 4) Gable Walls, 5) Holo (Diagonal Bracing), 6) 'Aho Pueo (Purlins), and 7) Ako (thatching). Each step is initiated by the parameter changes in the list index of all the assembly procedures as explained in Section 3.1 Initiation of AR + Assembly Procedures.

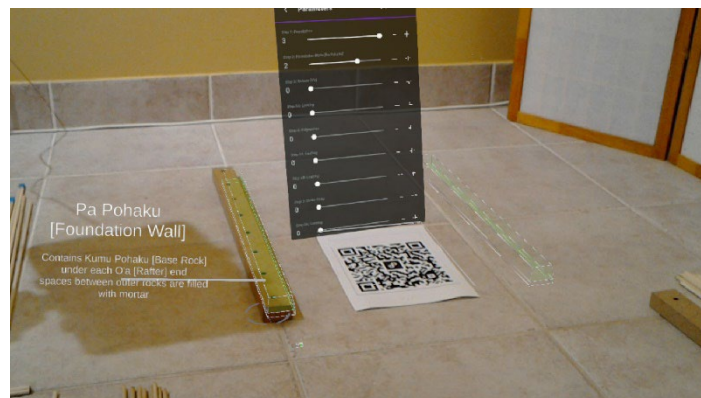

Figure 7. Placement of Pa Pohaku



#### 4.1. PA POHAKU

This step shares QR code location as the origin through AR to find where the pa pohaku would be built and placed upon. Pa Pohaku is a collection of local stones that are used to build up the foundation wall for a Hale. The pa pohaku is placed where the hologram is shown “green” as an indication of object placement. The completion of this step leaves the outline of the digital pa pohaku overlaying on the Pa Pohaku that was placed.

#### 4.2. O'A (RAFTER)

O'a, rafter, is highlighted in the assembly steps, one by one, additionally giving the user visual instructions on how to tie the lashing around each O'a.

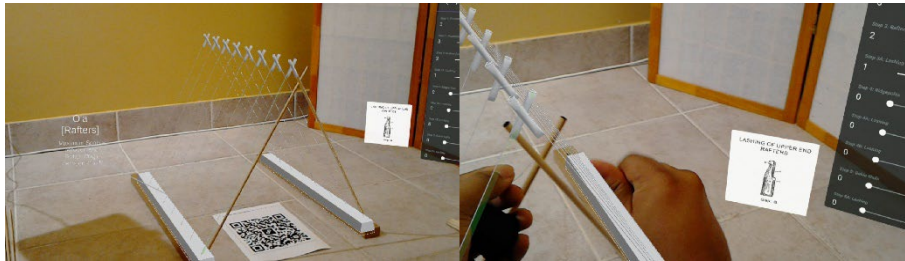

Figure 8. Diagram of Lashing Instruction of O'a

#### 4.3. POU HANA (RIDGE POST) + KAUHuhu (RIDGE POLE)

In the assembly, a Pou Hana (ridge post) is erected under the Kauhuhu (ridge pole) then lashed together. Following the lashing of the ridge post to the ridge pole, the Kua'iole (upper ridge pole) is then placed on top between the O'a and lashed together with the Kauhuhu. The lashing of the two ridgepoles is explained with the diagrams.

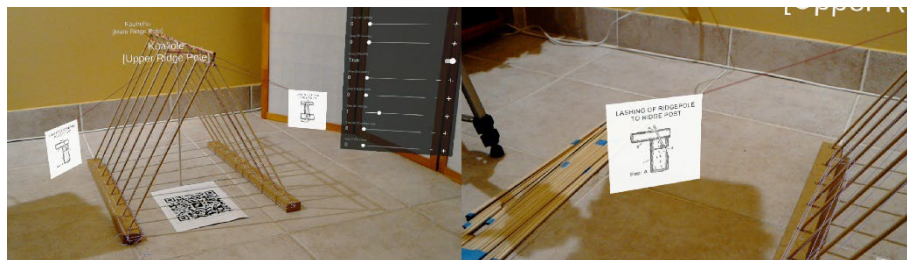

Figure 9. Lashing Instructions of Pou Hana (Ridge Post) and Kauhuhu (Ridge Pole)

#### 4.4. GABLE WALLS

The gable is attached to the O'a and Kauhuhu on the ends of the model. Each gable wall is comprised of a Kalapau (gable end tie), two Kukuna li'i (upper wall post), and a Kuponono (gable ridge pole). After the Kalapau and Kuponono are lashed on to the model, the Kukuna li'i gets lashed to the Kalapau and the O'a.

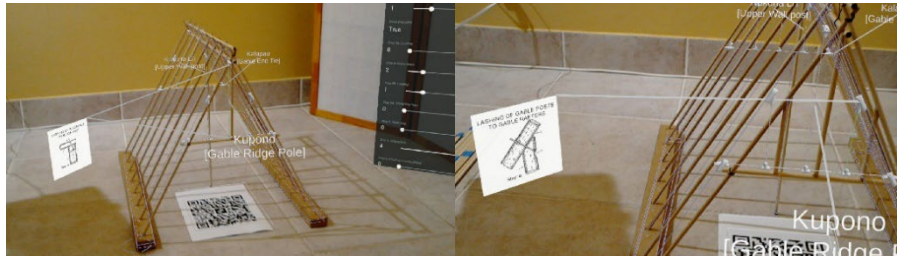

Figure 10. Lashing Instructions of Pou Hana (Ridge Post) and Kauhuhu (Ridge Pole)

#### 4.5. HOLO (DIAGONAL BRACES)

The Holo means the diagonal braces that are lashed to the O'a starting from one end up near the Kauhuhu down to the Pa Pohaku. The Holo provides the structural stability with keeping the O'a from shifting over time.

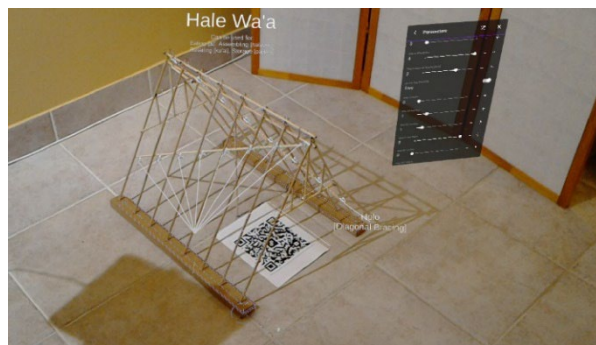

Figure 11. Holo (Diagonal Bracing) in the AR Assembly Process

#### 4.6. 'AHO PUEO + AKO (THATCHING)

The 'Aho Pueo (Purlins) are used to attach thatching on to the Hale. Purlins span horizontally across the O'a, then lashed vertically lined up with the O'a with the horizontal purlins in between. This spacing additionally benefits the Hale by keeping the thatching from making direct contact with the O'a.

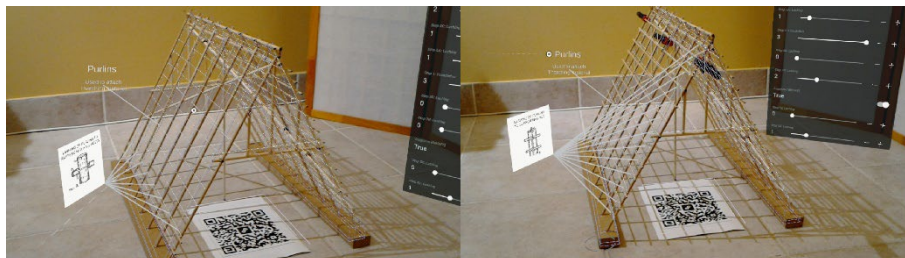

Figure 12. Assembly Placement of Horizontal and Vertical Purlins Against O'a



Depending on the specific thatching material there are a few different ways the thatching can be attached to the Hale. Thatching could be made with pili grass bundle, pandanus leaves, ti leaves, and more depending on the resources of the location where the Hale is being built. According to the selection of the material, the instructional diagram is provided for lashing the thatching to the purlins. The upper thatching is joined by overlapping with the purlin above it. The Thatching is then attached to the purlins on the side of the Hale.



Figure 13. User Assessing the Variety of Thatching Options of the Hale

## 5. Discussion

In the assembly of the Hale model, real-time feedback was achieved through the procedural steps toggled within the view of the Microsoft HoloLens. With cycling through each style from the library of digital Hale, a user can initiate the target of his/her investigation. The list of the selected Hale's assembly procedures allows the user to proceed. At each procedure, the wireframe of the partial components of the Hale is overlaid as a holographic guidance in an extended reality. Through the guidance, the user's hands-on interaction with two-dimensional and three-dimensional objects in between physical and virtual was intact and dynamic. The visualization of context-specific complex spatial relationships and abstract concepts is supported by text tags and diagrams generated within Fologram. The text tags provided the explanation of historical and cultural contents of each procedure. Furthermore, the diagrams overlaid with a given holographic wireframe of each procedure visualize more complicated steps such as join assembly, lashing, and thatching of the Hale. The learning experience by the proposed AR application using Microsoft HoloLens, a Head Mount Display, allows the user to get fully immersed into the assembly process of the Hale with sharing its cultural significance. The texture of Hale was not applied to the current application for providing an ease of visual access for the assembly of Hale. A toggle function for the texture is being developed for the representation of the Hale as a whole.

In this paper, the proposed AR based construction process provides a way of

learning through making and without being told verbally how to do so as a tool for teaching tacit knowledge embedded in the Hale. This hands-on learning experience would hopefully foster a deeper appreciation and understanding of Native Hawaiian culture and allow for further conservation of this indigenous knowledge.

## References

- Abernathy, J. E. and Suelyn C. T. (1983). *Made in Hawai'i*. University of Hawaii Press.
- Aikau, H. K., & Gonzalez, V. V. (2019). Kūkulu Hale in Hāna, East Maui: Reviving Traditional Hawaiian House and Heiau Building. In *Detours: A decolonial guide to hawai'i* (pp. 211-219). Duke University Press, NC: Durham.
- Apple, R. A. (1971). *The Hawaiian Thatched House*. Island Heritage.
- Arvanitis, T. N., Petrou, A., Knight, J. F., Savas, S., Sotiriou, S., Gargalacos, M.(2007). Human factors and qualitative pedagogical evaluation of a mobile augmented reality system for science education used by learners with physical disabilities. *Personal and Ubiquitous Computing*, 13(3), 243–250.
- Bekele, M. K., Pierdicca, R., Frontoni, E., Malinverni, E. S., & Gain, J. (2018). A survey of augmented, virtual, and mixed reality for Cultural Heritage. *Journal on Computing and Cultural Heritage*, 11(2), 1-36. doi:10.1145/3145534
- Bryan, E. H. (1950). "6. The Home." in *Ancient Hawaiian Life*. Books about Hawaii.
- Buck, P. H. (1957). *Arts and Crafts of Hawaii*. Bishop Museum Special Publication.
- Caudell, T.P. and Mizell, D.W. (1992). Augmented Reality: an Application of Heads-up Display Technology to Manual Manufacturing Processes. In *Proceedings of the 25th Hawaii International Conference on System Sciences* (pp. 659-669).
- Cozzani, G., Pozzi, F., Dagnino, F. M., Katos, A. V., & Katsouli, E. F. (2016). Innovative Technologies for Intangible Cultural Heritage Education and preservation: The case of I-treasures. *Personal and Ubiquitous Computing*, 21(2), 253-265. doi:10.1007/s00779-016-0991-z
- Edwards, J. (2019, March 25). *Social Structure: Hawaiian Hale*. Hawaiian Science and Technology. Maui Magazine. Retrieved December 12, 2019, from <https://www.mauimagazine.net/hawaiian-hale/>
- Dampney, K., Busch, P. and Richards, D. (2002). The Meaning of Tacit Knowledge. *Australasian Journal of Information Systems*, 10(1), 3-13
- Gonzales Vargas, J.C., Fabregat, R., Carrillo-Ramos, A., Jové, T. (2020). Survey: Using Augmented Reality to Improve Learning Motivation in Cultural Heritage Studies. *Applied Sciences*, 10(3):897
- Hashimoto, J., and Park, H-J. (2020). Dance with Shadows: Capturing tacit knowledge with smart device augmented reality (SDAR). In *Proceedings of the 38th eCAADe: Anthropologic: Architecture and Fabrication in the cognitive age* (Vol 2, pp. 165-172).
- Kilolani, M. D., and Middlesworth, N. (1992). "Unit 14: Thatched Houses and Other Structures." *Essay. In Resource Units in Hawaiian Culture*, The Kamehameha Schools Press, 197-212
- Nakata, S. (2017). Language Suppression, Revitalization, and Native Hawaiian Identity. *Diversity & Social Justice Forum*, Volume 3, 14-27.
- Nonaka, I. and Takeuchi, H. (1995). *The Knowledge-Creating Company How Japanese Companies Create the Dynamics of Innovation*. Oxford University Press.
- Voinea, G., Gîrbacia, F., Postelnicu, C. C., & Marto, A. (2018). Exploring cultural heritage using augmented reality through Google's Project Tango and arcore. *Communications in Computer and Information Science*, 93-106. doi:10.1007/978-3-030-05819-7\_8
- Warschauer, M., Donaghy, K., & Kuamojo, H. (1997). Leoki: A powerful voice of Hawaiian language revitalization. *Computer Assisted Language Learning*, 10(4), 349-361. doi:10.1080/0958822970100405